

Gouging torch

K10 / K12 / K12 T / K16 / K16 T / K20

Reliable and safe ...

The original KURT HAUFE gouging torch is used for gouging, joint preparation, removing of pores and cracks, chamfering, cutting, surface treatment and hole piercing at all metals. They stand out due to their reliability and safety.

Special features:

- Oval, rugged, heat insulated handle
- Regulation of compressed air via rotary valve
- High air consumption
- High flex cable
- T-version with swivel joint
- Turnable nozzle suitable for round and flat electrodes



Technical data

Type	Rating	Duty cycle	Round electrode-Ø	Flat electrode		Compr. air max.	Compr. air connection
				width (mm)	thickness (mm)		
K10	500 A	60%	4-10 mm	15 / 20	4	10 bar	3/8"-18 NPT
K12 / T	600 A	60%	4-12 mm	15 / 20	4-5	10 bar	3/8"-18 NPT
K16 / T	1000 A	60%	8-16 mm	15 / 20 / 25	4-5	10 bar	3/8"-18 NPT
K20	1500 A	60%	8-19 mm	15 / 20 / 25	4-5	10 bar	3/8"-18 NPT

Gouging torch cpl.

Type		Part-No.	
		2.1 m	3.0 m
Gouging torch K10	cpl. with cable assembly	516.D124	516.D001
Gouging torch K12	cpl. with cable assembly	516.D125	516.D002
Gouging torch K12 T	cpl. with cable assembly	516.D154	516.D142
Gouging torch K16	cpl. with cable assembly	516.D126	516.D003
Gouging torch K16 T	cpl. with cable assembly	516.D155	516.D150
Gouging torch K20	cpl. with cable assembly	-	516.D167.1

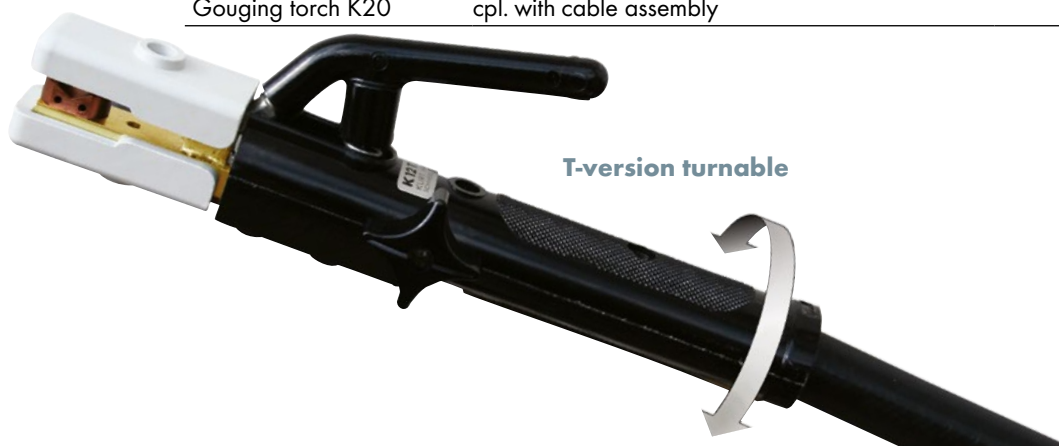

T-version turnable

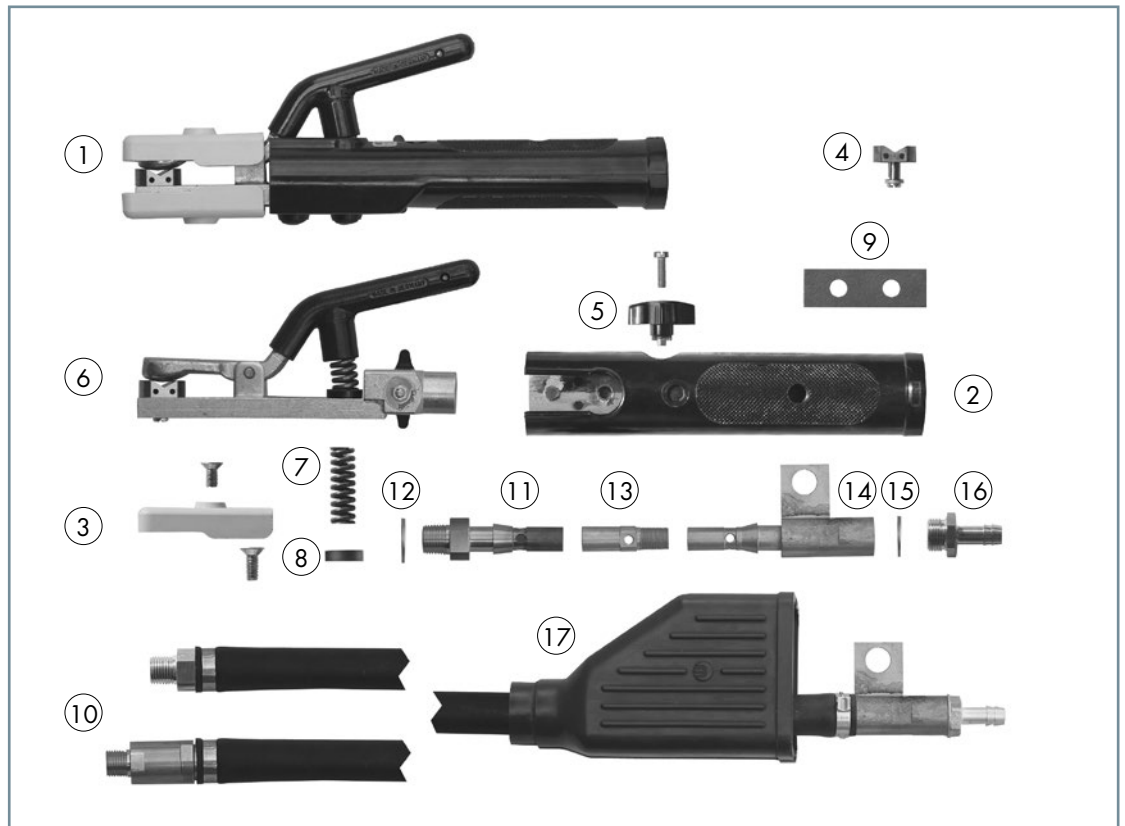

Wear parts

Pos.	Description	Part-No.					
		K10	K12	K12 T	K16	K16 T	K20
1	Gouging torch w/o tube cable	516.D028	516.D028	516.D028	516.D040	516.D040	516.D195.1
2	Handle	516.D011	516.D011	516.D011	516.D011	516.D011	516.D011
3	Insulating flange (2 pcs.)	512.D091	512.D091	512.D091	516.D042	516.D042	516.D196.2
4	Nozzle for round electrodes (5 pcs.)	516.D026	516.D026	516.D026	516.D044	516.D044	516.D044
5	Cross handle	516.D012	516.D012	516.D012	516.D012	516.D012	516.D012
6	Front part cpl.	516.D027	516.D027	516.D027	516.D041	516.D041	516.D168.1
7	Pressure spring	516.D013	516.D013	516.D013	516.D013	516.D013	516.D013
8	Cap (5 pcs.)	512.D036	512.D036	512.D036	512.D036	512.D036	512.D036
9	Insulating plate	512.D032	512.D032	512.D032 ¹	512.D032	512.D032 ¹	512.D032
10	Tube cable cpl. for 2.1 m	516.D127	516.D129	516.D156	516.D130	516.D157	-
	Tube cable cpl. for 3.0 m	516.D050	516.D018	516.D143	516.D048	516.D151	516.D197.1
11	Connection piece	516.D051	516.D022	-	516.D043	-	516.D043
12	Space ring (10 pcs.)	516.D053	516.D053	516.D053	516.D053	516.D053	516.D053
13	Inside connection	-	516.D160	516.D160	516.D161	516.D161	516.D161
14	Connection piece	516.D135	516.D158	516.D158	516.D158	516.D158	516.D158
15	Space ring (10 pcs.)	001.D170	001.D170	001.D170	001.D170	001.D170	001.D170
16	Threaded nozzle	001.D171	001.D172	001.D172	001.D172	001.D172	001.D172
17	Insulating joint	516.D134	516.D134	516.D134	516.D134	516.D134	516.D134
not ill.	Special hose for 2.1 m	516.D128	516.D131	-	516.D131	-	-
	Special hose for 3.0 m	516.D055	516.D021	-	516.D021	-	516.D021
not ill.	Flat nozzle 15/20 (5 pcs.)	516.D023	516.D023	516.D023	516.D023	516.D023	516.D023
not ill.	Flat nozzle 15/20 15 (5 pcs.)	516.D024	516.D024	516.D024	516.D024	516.D024	516.D024
not ill.	Flat nozzle 15/20 20 (5 pcs.)	516.D025	516.D025	516.D025	516.D025	516.D025	516.D025
not ill.	Flat nozzle 15/20 25 (5 pcs.)	-	-	-	516.D045	516.D045	516.D045

¹ K12 T and K16 T require 2 insulating plates (512.D032) each.

Gouging torch TEAM BINZEL®

G 3000 / G 4000

Rugged and easy to handle ...

The TEAM BINZEL® gouging torches G 3000 and G 4000 are safe and easy to handle. They are designed to be used for gouging, weld seam preparing, gouging out of blowholes and cracks, chamfering, cutting, surface resurfacing and keyhole cutting for all common materials.

Special features:

- Rugged and heat resistant handle
- Turnable nozzle suitable for round and flat electrodes
- High air consumption
- High flex cable
- Swivel joint



Technical data

Type	Rating	Duty cycle	Nom. air pressure	Nom. volume flow	Connection air supply
G 3000	max. 600 A	60%	7 bar	approx. 0.60 m ³ / min.	3/8"-18 NPT
G 4000	max. 1000 A	35%	7 bar	approx. 0.70 m ³ / min.	3/8"-18 NPT



**Gouging torch
TEAM BINZEL®
G 3000**



Type	Part-No.
Gouging torch TEAM BINZEL® G 3000 (torch only)	516.0001
Gouging torch TEAM BINZEL® G 3000 cpl. with cable assembly (length = 2.1 m)	516.0002
Gouging torch TEAM BINZEL® G 3000 cpl. with cable assembly (length = 3.0 m)	516.0003
Cable assembly, length = 2.1 m	516.0004
Cable assembly, length = 3.0 m	516.0005

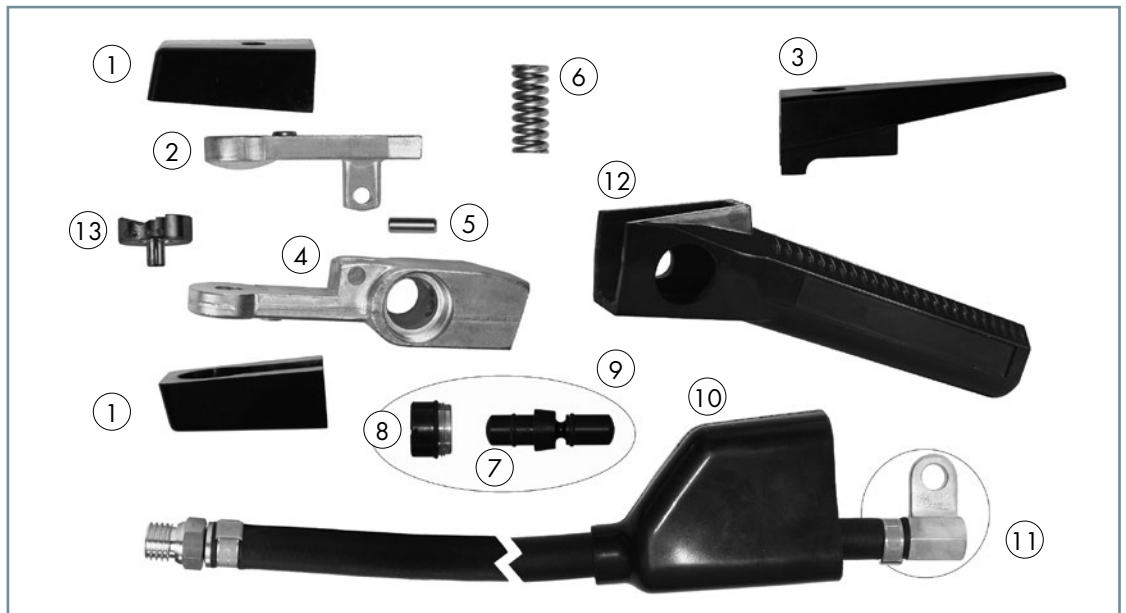

Wear parts

Pos.	Description	Part-No.
1	Insulator set (2 pcs.)	516.0006
2	Lever top part	516.0007
3	Lever	516.0008
4	Torch body	516.0009
5	Bolt	516.0010
6	Pressure spring	516.0011
7	Slider	516.0012
7	Slider with O-ring	516.0013
7	O-ring (2 pcs.)	516.0014
8	Fastening nut	516.0015
9	Valve cpl.	516.0016
10	Insulating part	516.0017
11	Connector	516.0018
12	Handle	516.0019
13	Flat nozzle	516.0020

Gouging torch TEAM BINZEL®

G 3000 / G 4000

Gouging torch
TEAM BINZEL®
G 4000



Type	Part-No.
Gouging torch TEAM BINZEL® G 4000 (torch only)	516.0022
Gouging torch TEAM BINZEL® G 4000 cpl. with cable assembly (length = 2.1 m)	516.0023
Gouging torch TEAM BINZEL® G 4000 cpl. with cable assembly (length = 3.0 m)	516.0024
Cable assembly, length = 2.1 m	516.0025
Cable assembly, length = 3.0 m	516.0026

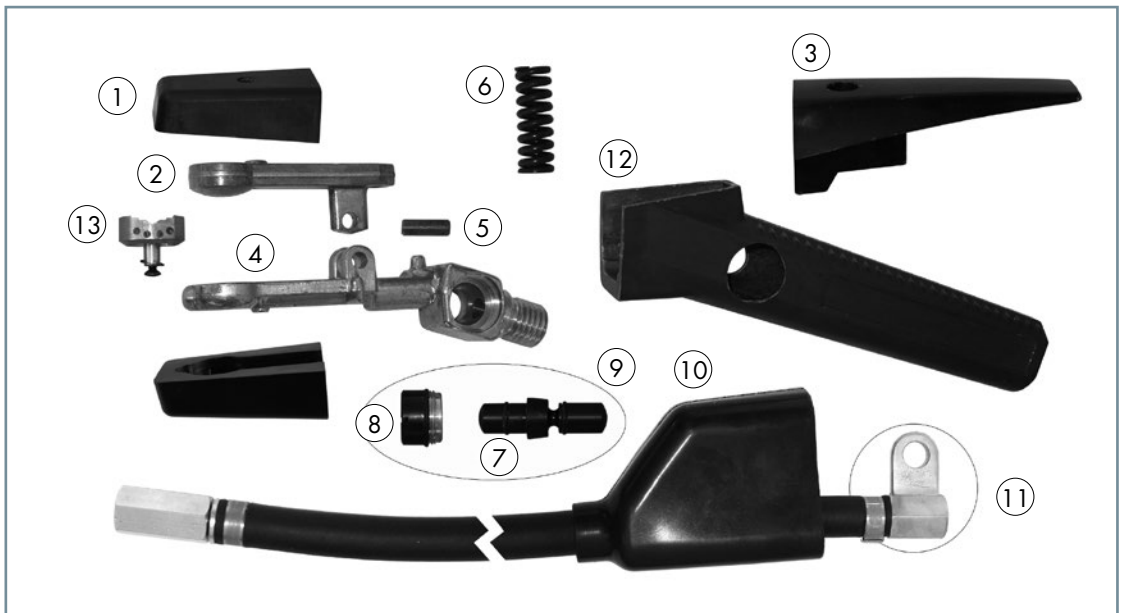

Wear parts

Pos.	Description	Part-No.
1	Insulator set (2 pcs.)	516.0027
2	Lever top part	516.0028
3	Lever	516.0029
4	Torch body	516.0030
5	Bolt	516.0031
6	Pressure spring	516.0032
7	Slider	516.0012
7	Slider with O-ring	516.0013
7	O-ring (2 pcs.)	516.0014
8	Fastening nut	516.0015
9	Valve cpl.	516.0016
10	Insulating part	516.0017
11	Connector	516.0018
12	Handle	516.0033
13	Flat nozzle	516.0034